



2100 SERIES INSTALL GUIDE PLUG-IN ROOM HEATER

NOTE: Always transport the heater in an upright position to avoid damage to internal components and insulation materials.

1 PERSONAL SAFETY INSTRUCTIONS

SAFETY ALERT SYMBOLS

Three safety alert symbols are used to alert you to personal safety instructions. They are:

- Electrical (1)
- Mechanical (2)
- Fire (3)

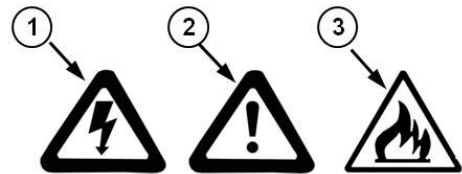

SIGNAL WORDS

Signal words that appear next to safety alert symbols are:

- **DANGER**
- **WARNING**
- **CAUTION**
- **IMPORTANT**
- **NOTE**

Carefully read and understand the instructions before you continue.

DANGER indicates a hazardous situation which, if not avoided, will result in death or serious injury.

WARNING indicates a hazardous situation which, if not avoided, could result in death or serious injury.

CAUTION indicates a hazardous situation which, if not avoided, could result in minor or moderate injury.

IMPORTANT

- The equipment described herein is intended for installation by a qualified technician in compliance with applicable local, state, and national codes and regulations.
- **Disclaimer:** In compiling this manual, Steffes has used its best judgement based upon information available, but disclaims any responsibility or liability for any errors or miscalculations contained herein, or any revisions hereof, or which result, in whole or in part, from the use of this manual or any revisions hereof.

2 SAFETY PRECAUTIONS

1. DO fully assemble the heater before energizing.
2. DO keep all explosive materials and/or flammable gases away from the heater.
3. DO maintain the placement and clearance requirements (Section 4).
4. DO keep items away from the discharge air grill area of the heater.
5. DO contact a qualified service technician for installation of this heater to ensure it is installed in accordance with information contained herein and with national, state, and local codes and regulations.

3 IDENTIFY HEATER TYPE

Steffes heaters are available for connection to different input voltages. Standard configuration for direct-wired heaters is 240V; cord-connected heaters are configured to plug into a 120V wall outlet. To determine the configuration of the heater, refer to the Unit Identification Label on the lower left side panel. All heaters are UL and cUL safety listed.

Determine the type of heater:

- 120V Plug-In.
- 240V direct-wire. See 1206094 Install Guide for 240V direct-wire heaters.

Determine the method of peak control being used. This will determine what controls are required, and how the heater will be installed and programmed.

- Power Line Carrier (PLC)
- Low Voltage Wiring
- Steffes Time Clock Module
- Line Voltage Wiring



Electric Air Heater
3P23



Model (Modèle)	A	Options	C			
Serial No. (No de série)	B					
Charge Circuit #1 (Circuit de charge #1)	D	Volts (V)	E	Watts (W)	F	Hz
Charge Circuit #2 (Circuit de charge #2)	G	Volts (V)	H	Watts (W)	I	Hz
Fan/ Controls Circuit (Circuit de commande)	J	Volts (V)	K	Watts (W)	L	Hz

Clearance Requirements (Exigences de dégagement)

Allow a minimum of two (2) inches on sides, one and a half (1.5) inches on back, four (4) inches on top and fifteen (15) inches on front of unit. DO NOT enclose or obstruct access to the heater's front panel and grill.
(Prévoyez un minimum de deux (2) pouces sur les côtés, un pouce et demi (1,5) à l'arrière, quatre (4) pouces sur le dessus et quinze (15) pouces à l'avant de l'appareil. NE PAS entourer d'une enceinte ni obstruer l'accès au panneau avant et à la grille du générateur d'air chaud.)

WARNING: VIOLATION OF THE REQUIRED CLEARANCES MAY CREATE A HAZARDOUS CONDITION.

(AVERTISSEMENT: LE NON RESPECT DES DÉGAGEMENTS REQUIS PEUT ENGENDRER UNE CONDITION DANGEREUSE.)

Label 1200501 Rev 2

Sample Unit Identification Label

4 DETERMINE INSTALLATION LOCATION (PLACEMENT AND CLEARANCES)

There are minimum clearances that must be considered when choosing a location. These areas surrounding the heater must be kept open and free of debris. Verify the floor is structurally sound and can support the weight of the heater.

MINIMUM CLEARANCES:

- A** Top = 4 inches
- B** Front and Grill = 15 inches
- C** Sides = 2 inches*
- D** Back = 1-1/2 inches

* A clearance of at least 12" is recommended on the right side of heater. If there is less than a 12" clearance, a remote room temperature sensor is recommended to ensure accurate room temperature sensing. The 12" clearance also allows space for hinging the right side panel open for servicing.

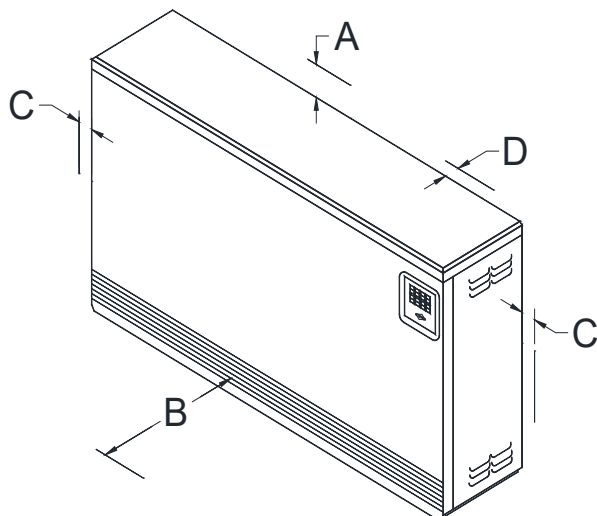

WARNING

Risk of fire. Can cause injury or death. Violation of the clearance requirements can cause improper operation of the equipment. Maintain the placement and clearance requirements specified.

Model	Installed Weight (lbs)	# of Brick Pkgs
2102PI	281	8

NOTE: Special requirements must be considered if placing the heater in a garage or other area where combustible vapors may be present. Consult local, state, and national codes and regulations to ensure proper installation.

5 INSTALLATION

1. Remove the heater from the box and lift it off the shipping pallet. Place the shipping box aside until the brick loading process (Section 9).
2. Locate Install Guide, registration card, and brick loading tool. These items are shipped on the top of the heater.
3. Remove the base (Figure 3) from the back of the heater. This base **MUST** be attached to the bottom of the heater.
4. Remove the screws along the lower edge of the painted front panel.
5. Pull the lower edge of the panel forward and unhook it from the top panel. Carefully place the painted front panel aside to avoid damage.

NOTE: No heater panel, with the exception of the painted front panel and painted right side panel, can ever be removed from the heater. Should any other exterior panel(s) be removed, the heater must be taken out of service permanently. All panels must be in place when operating the heater.

6. Hinge the right side panel open by A) removing the screw located above the grill slats on the lower right side of the heater, B) loosening the screw located at the top right corner of the electrical compartment, and C) pushing out the right side panel. Refer to Figure 1.
7. Remove the security base hardware kit (Figure 2) from inside the electrical compartment.
8. Gently lay the heater on its back. For ease of installation, slightly elevate the bottom of the heater.
9. Align the holes in the security base with the pre-drilled holes in the bottom of the heater. Using the six #14 x 1-1/4" sheet metal screws and washers provided in the mounting hardware package, attach the security base to the painted bottom panel.

NOTE: The angled corners of the security base will be towards the front of the heater and the painted side of the security base faces up.

10. After the base is attached, return the heater to its upright position and place in desired location. Do NOT energize the heater until installation is complete.



WARNING

Risk of fire. Can cause injury or death. Failure to secure the heater can cause the heater to fall over. Properly secure the heater by using the wall support bracket to mount it to the wall.

FIGURE 1

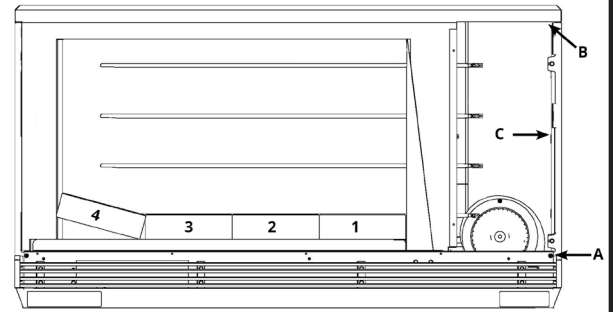
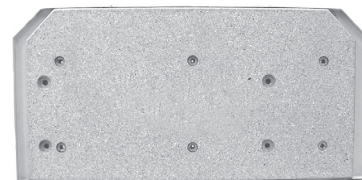

FIGURE 2



FIGURE 3



6

CONNECTING PLUG-IN HEATER

WARNING



• **HAZARDOUS VOLTAGE:** Risk of electric shock. Can cause injury or death. **DO NOT** energize the heater until installation is complete. Equipment must be installed by a qualified technician in accordance with applicable local, state, and national codes and regulations.



• **Risk of fire.** Can cause injury or death. Poor or marginal electrical connections will cause the connections to overheat and fail. Use extreme caution when making all electrical connections.

All cord-connected heaters are factory-configured to be plugged into a 120V wall outlet. The circuit outlet the heater is plugged into should be designated solely to the heater for circuit sizing purposes. In some instances it is required for peak control and metering purposes. To determine the correct circuit size, refer to the Field Connection Wire and Circuit Breaker Sizing Guide.

120V cord-connected room heaters must only be used with receptacles that are of the grounding type and suitable of the load of the heater.

The heater's cord has a plug, as shown. An adaptor, shown below, is available for connecting three-blade grounding type plugs to two-slot receptacles. The green grounding means extending from the adaptor must be connected to a permanent ground, such as properly grounded outlet box. This adaptor should not be used if a three-slot grounded receptacle is available.

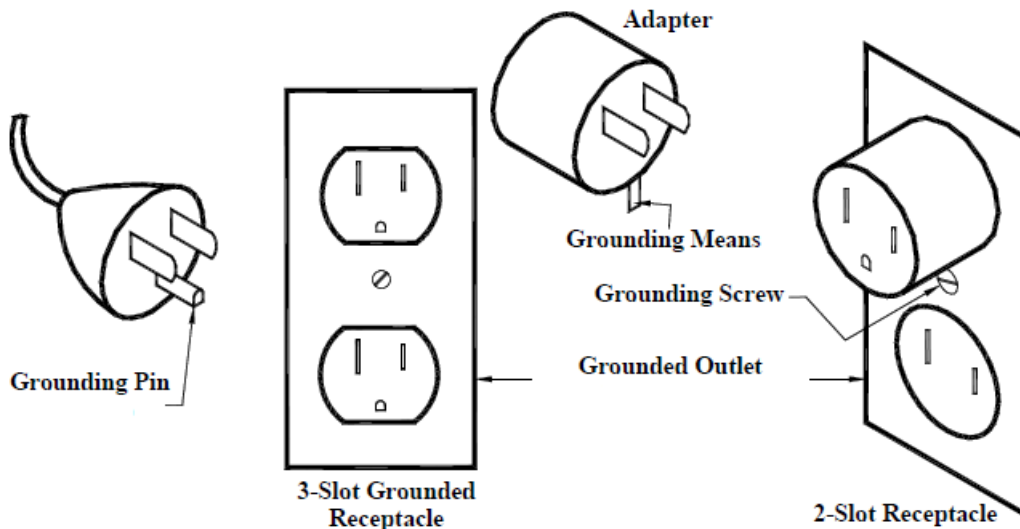

7 PEAK CONTROL METHOD

POWER LINE CARRIER (PLC) PEAK CONTROL

The 2100 series room heater is factory-configured for use with power line carrier (PLC) control. The PLC transceiver (sold separately) sends peak control and outdoor temperature information to all the heaters in the building, eliminating the need for low voltage wiring to each heater.

LOW VOLTAGE CONNECTIONS FOR DIRECT WIRED CONTROLS

If using the low voltage control option, the heater is direct wired to the power company's peak control switch. Field connections from the switch are made to the heater's low voltage wiring harness through the low voltage raceway. These wires are also accessible from inside the electrical compartment.

SINGLE HEATER

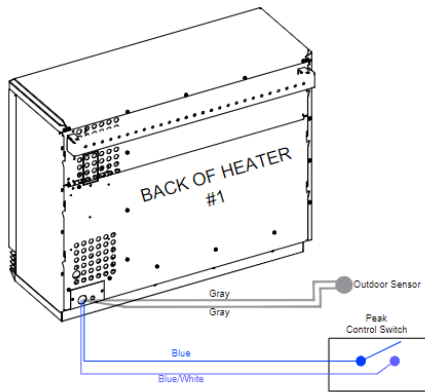

TWO HEATERS

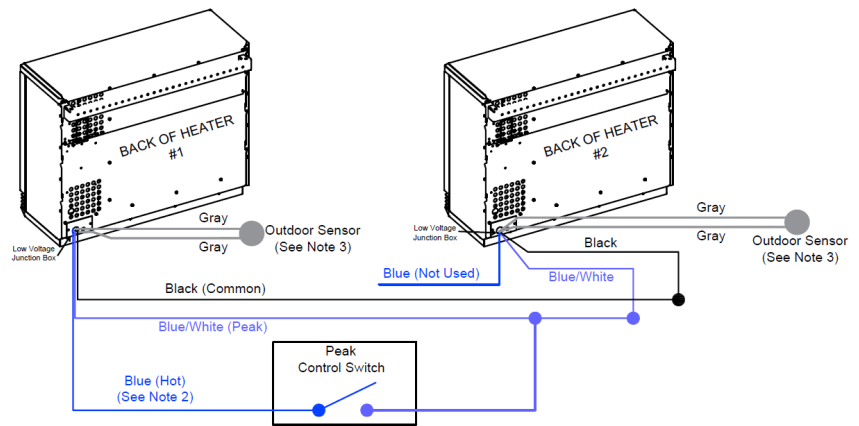

NOTES:

1. Class II (low voltage) wiring should never enter a line voltage area of the heater, including its umbilical cord.
2. Connecting the low voltage hot (blue) wire from multiple heaters to a single control switch may cause damage to the heater. In multiple heater applications, connect the wires as shown for proper operation.
3. In multiple heater applications, one outdoor sensor is needed for each heater installed.
4. If routing low voltage wire near line voltage conductors, shielded wire must be used.

TIME CLOCK MODULE PEAK CONTROL

The Steffes Time Clock Module (part #130104) is another option for providing a peak control signal to the heater. Peak control times are programmed into the heater to enable this device. Refer to the instructions provided with the time clock module for more information on the installation and operation of this device.

LINE VOLTAGE PEAK CONTROL

Line voltage control is a method that employs the use of an external switching device to disconnect line voltage to the charging circuit(s) during the peak times. If line voltage control is used, the blower/control circuit of the heater must be powered with a separate, uninterrupted, circuit. The display on the heater will continuously display an operating mode of "C" (charge), regardless of whether it is an off-peak or on-peak time.

8 LOW VOLTAGE - OUTDOOR TEMPERATURE SENSOR (OPTIONAL)

The outdoor sensor monitors outdoor temperature and provides this information to the heater. The heater responds by automatically storing heat in its brick core according to outdoor temperature and the heating requirements.

Installation Methods:

A) Hard-wired to the heater (one sensor per heater required)

OR

B) Connected to the Power Line Carrier (PLC)

Location of: The outdoor sensor must be placed in a location where it can accurately sense outdoor temperature and is not affected by direct sunlight or other abnormal temperature conditions.

Wiring to heater:

- Route low voltage wire from the outdoor sensor to the electrical compartment through one of the low voltage wire knockouts.
- Connect to the two gray wires in the low voltage raceway.
- Mount the sensor using the bracket provided.
- If the sensor wiring is routed through an external wall, the opening through which the wire is routed MUST be sealed. Failure to do so may affect the accuracy of the outdoor temperature sensor.
- The outdoor sensor can be extended up to a total of 250 feet if needed.
- Unshielded Class II (thermostat) wire can be used as extension wire as long as it is segregated from any line voltage cabling.
- No other loads can be controlled or supplied through this cable. It is for connection of the outdoor sensor ONLY.
- This low voltage cable MUST not enter any line voltage enclosure.

IMPORTANT

If connecting to the Steffes power line carrier (PLC) system, refer to the PLC Owner's and Installer's Guide.

9 BRICK LOADING

IMPORTANT

- **The heater MUST be securely mounted to the base prior to brick loading.**
- **Install bricks carefully to avoid damage to the bottom and back insulation panels of the storage cavity.**
- **Maintain an even horizontal line across the brick core during brick installation so air flow through the heater is not obstructed.**
- **To properly seal the brick core, verify all bricks are installed correctly.**

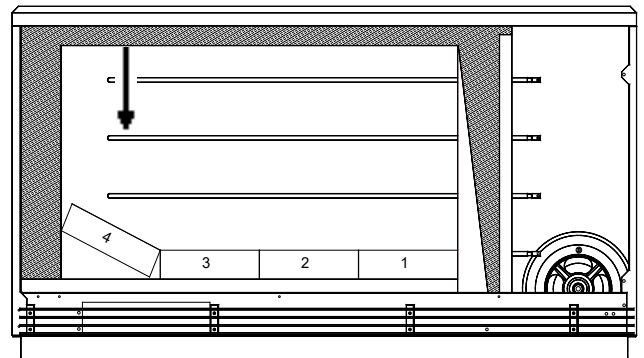

1. Verify you have the correct number of bricks for your application. Ceramic bricks are shipped separately and come two bricks per package.
2. Verify the heater is not energized.
3. Place shipping box in front of the heater for ease in cleanup of brick debris.
4. Remove the screws on the right side of the galvanized front panel. Rotate the panel to the left to remove.
5. Model 2104, 2105, or 2106 - remove and discard the cardboard spacer(s) from the brick core.
6. Install the first brick face up and slide to the far right side of the heater's storage cavity. Verify the grooved side of the brick is up and fits tight against the right air channel and the back insulation panel. Continue loading the bricks for Row 1. The insulation on the left side may need to be compressed to install the last brick on each row.

CONTINUED on PAGE 7

BRICK LOADING, CONTINUED

Note: Row 8 brick faces down

7. All bricks in rows one through seven must be loaded with the grooved side up.
8. Using the brick installation tool provided, install the eighth (top) row of bricks with the grooved side of the bricks facing down.
9. Reinstall the galvanized front panel.

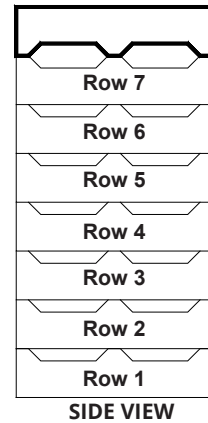
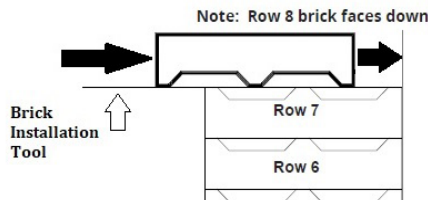

10 CONFIGURATION MENU

The Steffes 2100 Series room heaters have a Configuration Menu, which allows the heaters to be customized for the equipment installed and the power company consumers' needs. This menu can be accessed on start-up and allows configuration settings to be easily adjusted.

IMPORTANT

If access to Configuration Menu times out, the heater must be powered off at the circuit breaker and back on to re-enter the menu.

To access the Configuration Menu:

- Step 1 Energize the heater. Access to the Configuration Menu is allowed for the first two (2) minutes of operation. If the heater has been energized for over two (2) minutes, it must be powered off and back on again.
- Step 2 Press and release the M button until the faceplate displays "CONF."
- Step 3 Press the up arrow once and the faceplate will display "C000." The display will flash between "C000" and the corresponding configuration value.
- Step 4 If necessary, edit the configuration by pressing and holding the M button while using the up or the down arrow button to change the value.
- Step 5 Once the value is correct, release the buttons and press the up arrow button to go to the next configuration (C001, C002, etc.).
- Step 6 Repeat steps 4 through 5 until all configuration settings have been adjusted to the desired values.
- Step 7 Once configured, use the down arrow to leave the Configuration Menu.

In most applications only a few, if any, configuration changes will be necessary. The following is a chart showing the standard configuration settings for each method of peak control:

Configuration Number	Power Line Carrier (PLC) Peak Control *	Low Voltage Direct Wired Peak Control				Time Clock Module Peak Control		Line Voltage Peak Control	
		Peak Switch Closed for Charging		Peak Switch Open for Charging					
		Outdoor Sensor	No Outdoor Sensor	Outdoor Sensor	No Outdoor Sensor	Outdoor Sensor	No Outdoor Sensor	Outdoor Sensor	No Outdoor Sensor
C000	5	5	6	5	6	5	6	5	6
C001	60°F/16°C	60°F/16°C				60°F/16°C		60°F/16°C	
C002	20°F/7°C	20°F/7°C				20°F/7°C		20°F/7°C	
C003	Match to the Channel Selected at PLC	0				0		0	
C004	154	155	154	155	154	159	158	155	154
C005	0	1		0		0		0	
C006	6	6				6		6	
C007	30	30				30		30	
C008	5°F/-15°C	5°F/-15°C				5°F/-15°C		5°F/-15°C	
C009	5°F/-15°C	5°F/-15°C				5°F/-15°C		5°F/-15°C	
C010	90°F/32°C	90°F/32°C				90°F/32°C		90°F/32°C	
C011	70°F/21°C	70°F/21°C				70°F/21°C		70°F/21°C	
C012	60°F/16°C	60°F/16°C				60°F/16°C		60°F/16°C	
C013 - C021	N/A	N/A				Refer to the Time Clock Installation Instructions		N/A	

*Factory Default is Power Line Carrier (PLC) Peak Control using Channel 3

11 INSTALLER'S FINAL CHECK-OUT PROCEDURE

- Inspect field connections to ensure they are tight and wires are routed correctly.
- Check the damper system to ensure the damper operates freely and that there is no debris in this area, which could inhibit its operation. Slowly press the damper lever downward. Be careful not to bend the damper actuator. If the damper is not free, remove the blower and clean any debris from the damper.
- Verify the blower operates with a heat call. It may only run in low speed until the brick core heats up.
- With the heater in an off-peak (charge) mode, initiate the charge control override.
- Check for proper amperage draw on the charging circuit(s). Use the Charge Circuit Amperage Draw Chart for reference.
- Verify the heater receives and responds to the peak control device.
- Verify grill slats are positioned to direct airflow up, away from the floor.
- Secure the right side panel.
- Return the processor control board to its original position and install the painted front panel.
- Verify the configuration settings are correct for the application.
- **NOTE: On start-up, odors and/or small volumes of smoke relating to first time operation of the heating and blower components can occur.**
- Verify all fuses and/or circuit breakers are labeled in the breaker panel.
- Give the customer the User's Guide and warranty registration card. The registration card must be submitted to ensure warranty coverage.

WARNING



- Risk of electric shock. Can cause injury or death. This heater may be connected to more than one branch circuit. Disconnect power to all circuits before installing or servicing. DO NOT remove the painted front panel while energized. Equipment must be serviced by a qualified technician.



- Risk of fire. Can cause injury or death. ETS devices run for long periods of time at high electrical loads. Poor or marginal connections will cause the connections to overheat and fail.

CHARGE CIRCUIT AMPERAGE DRAW CHART

Input Watt- age (kW)	Voltage	Amp Draw
1.32	120	11.00

(Amp draw is calculated by taking the total input wattage divided by the input voltage. Allow +/- 5% tolerance at nominal input voltage.)